



VERTICAL TRAILER MIXERS

Single Auger | 8–16 m³

RMH single-auger trailers are compact, efficient, and tough. With a heavy-duty build, easy handling and low upkeep, they keep feeding smooth and predictable every day.



Perfect Mix

Single auger with up to 66 knives for uniform TMR and optimal fiber length.



Worldwide Service

Trusted components & dealer network ensure easy maintenance and maximum uptime.



DuraCore Construction

3CR12 stainless steel in high-wear zones for long life and uptime.



TMR

Homogeneous TMR, optimal fiber length for herd health.



Fuel Consumption

VOLVO engine at 1700 rpm with load-sensing hydraulics.



Time Saver

Efficient operation, less machines, less rounds.



Key features

Low PTO demand- works with modest horsepower (model-dependent).

Efficient mixing- single vertical auger with **contra-knives** for a fluffy, homogeneous TMR.

Compact footprint- easy to maneuver in small yards and narrow alleys.

Accurate discharge- electro-hydraulic door; **optional conveyors** to suit your bunk.

Low maintenance- simple driveline and **easy access** to service points.

Simple. Robust. Built for daily feeding.

TRAILERS Technical Specifications

SOLO

Model	Volume (M ³)	Augers	wheels	Dimensions (M)					
				Height (H)	Discharge Height		Length (L) *	Width	
					STD	door outlet		front conveyor	Bottom
Mixell 8L	8	1	10/75	2.35	0.76	0.61	5.16	2.25	2.25
Mixell 10	10	1	10/75	2.47	0.76	0.61	5.16	2.25	2.45
Mixell 12	12	1	10/75	2.79	0.76	0.61	5.22	2.25	2.45
Mixell 14	14	1	30/11.5	2.96	0.75	0.6	5.35	2.25	2.45
Mixell 16	16	1	30/11.5	3.13	0.75	0.6	5.40	2.25	2.83

* Rear discharge length reduced by 0.63 m

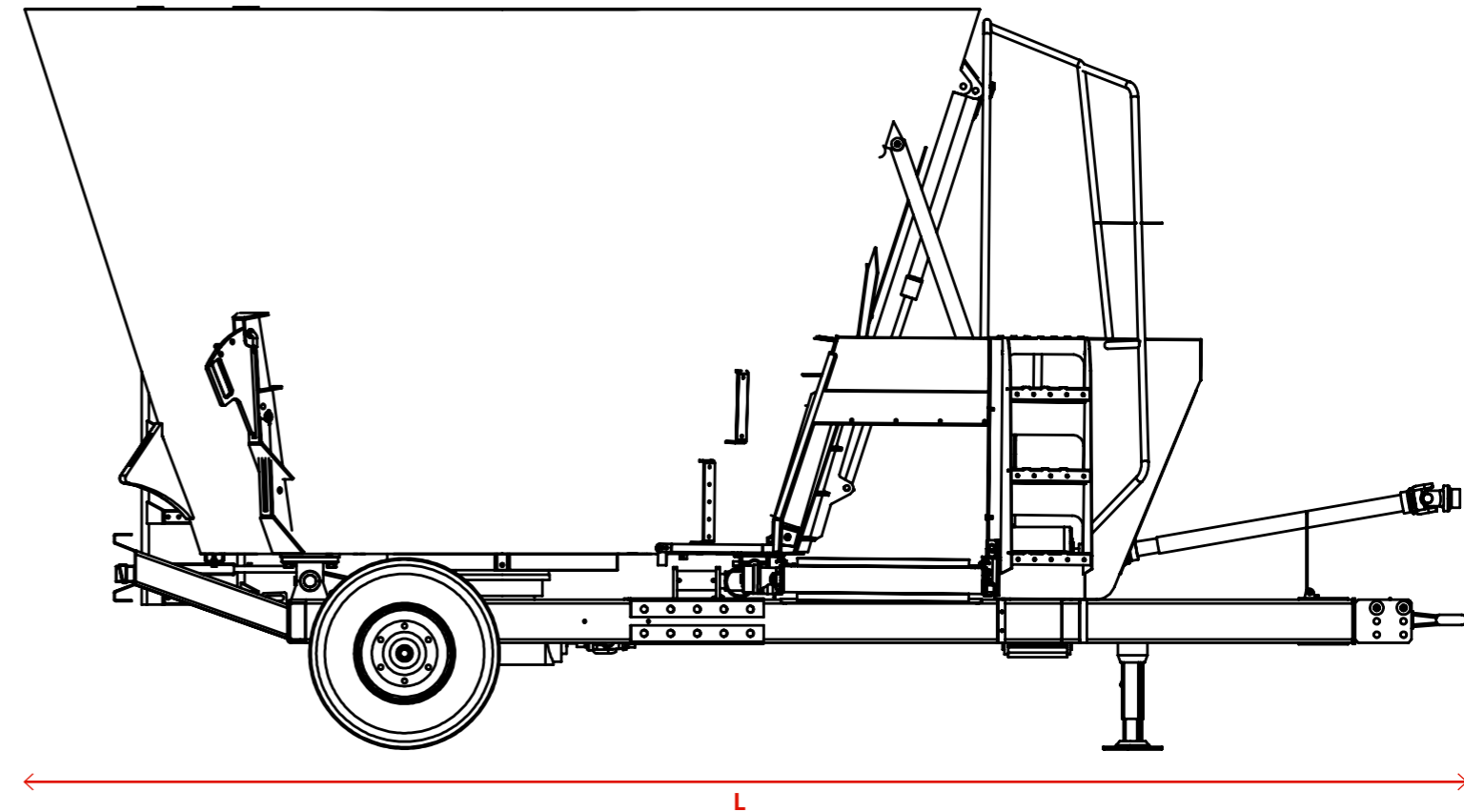
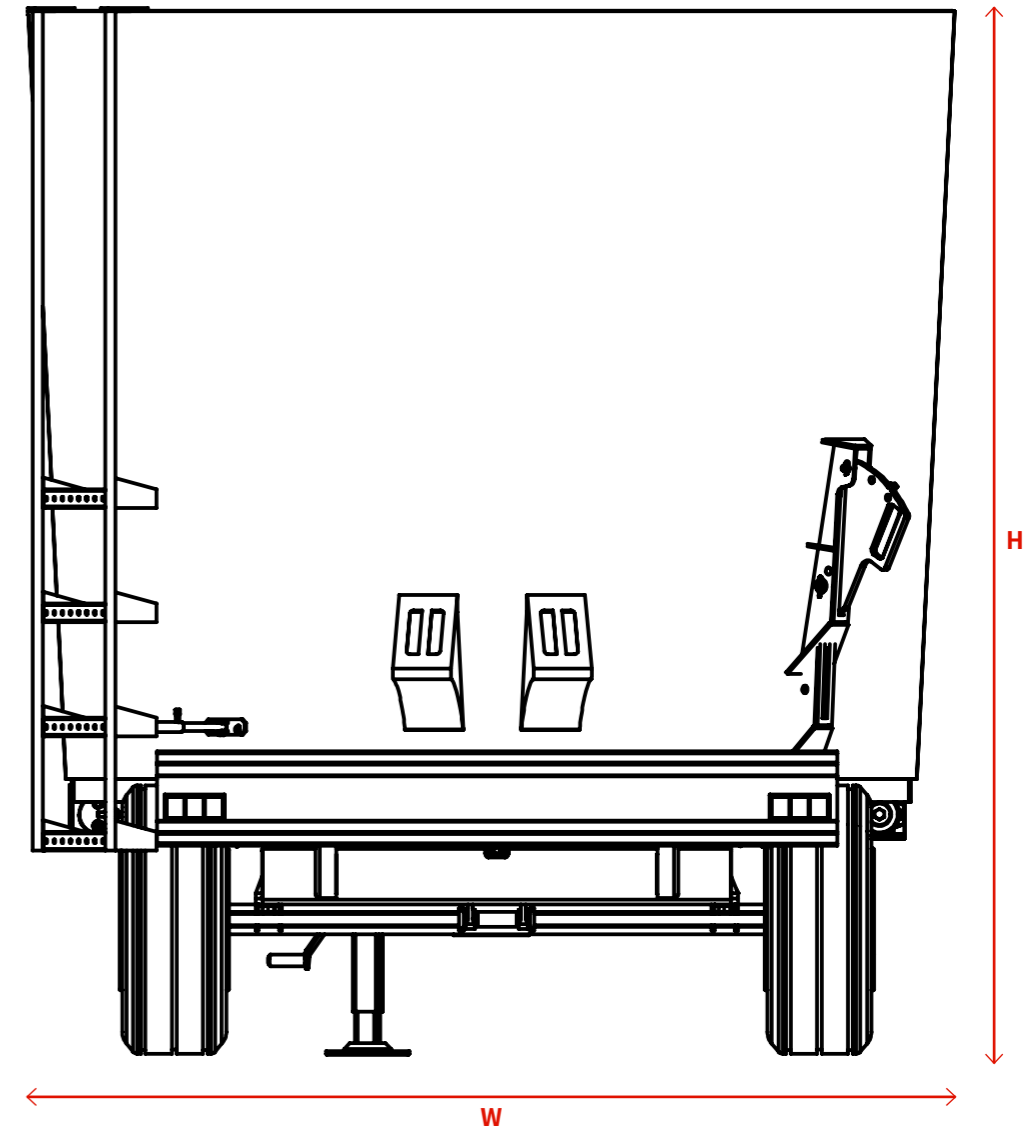

Twin Auger | 18–30 m³

Twin-auger trailers deliver higher capacity and faster, more uniform blending—perfect for farms that want efficiency without compromise.

Axle Options- built to match your routes

- Single axle:** agile in the yard, lower tare weight, simple upkeep.
- Tandem axle:** better load distribution and stability, smoother road travel at higher volumes, reduced tire wear.



Perfect Mix

Single auger with up to 66 knives for uniform TMR and optimal fiber length.



Worldwide Service

Trusted components & dealer network ensure easy maintenance and maximum uptime.



DuraCore Construction

3CR12 stainless steel in high-wear zones for long life and uptime.



TMR

Homogeneous TMR, optimal fiber length for herd health.



Fuel Consumption

VOLVO engine at 1700 rpm with load-sensing hydraulics.



Time Saver

Efficient operation, less machines, less rounds.



Key features

Two overlapping vertical augers- fast, consistent blending of fibrous rations.

Reinforced drivetrain- heavy-duty gearbox & auger drive for continuous work.

Ride & stability- single or tandem axle configurations to match load and terrain.

Flexible discharge- electro-hydraulic doors; multiple conveyor layouts.

Built for larger operations- ideal for medium–large herds with multiple rations/day.

Twice the mixing power. Maximum versatility.



TRAILERS Technical Specifications

DUO

Model	Volume (M ³)	Augers	Dimensions (M)						
			Bin (mm)	Height (H)			Length (L) *	Width	
				tyre diameter				front discharge*	Bottom
				0.95 (STD)	0.8	1.051			
single axle 445/R45	tandem axle 30/11.5	tandem axle 435/50							
Mixell 16	16	2	1.70	2.65	2.50	2.75	7.18	2.25	2.25
Mixell 18	18	2	1.72	2.67	2.52	2.77	7.24	2.25	2.45
Mixell 20	20	2	1.90	2.85	2.70	2.95	7.30	2.25	2.42
Mixell 22	22	2	2.10	3.05	2.90	3.15	7.36	2.25	2.44
Mixell 24	24	2	2.15	3.10	2.95	3.20	7.38	2.25	2.70
Mixell 26	26	2	2.29	3.24	3.09	3.34	7.42	2.25	2.73

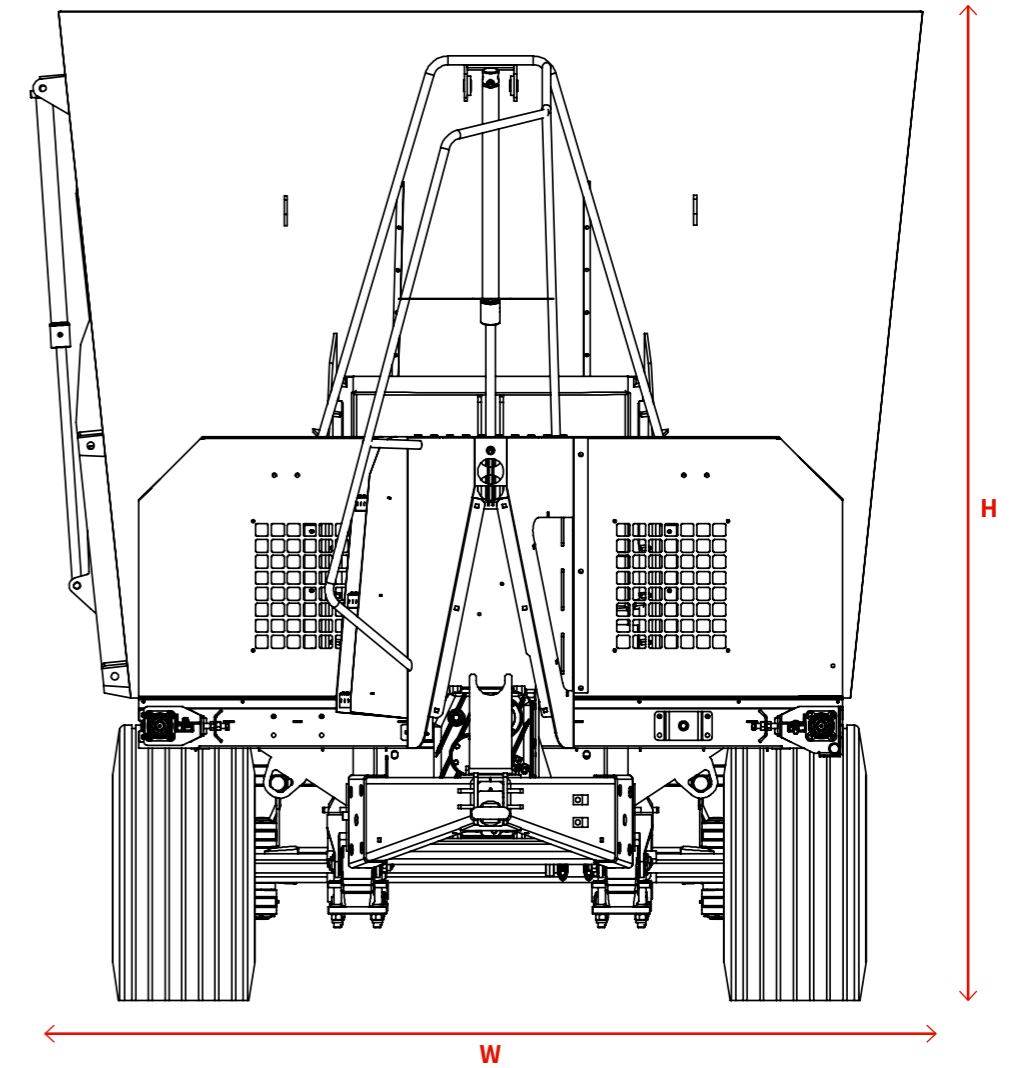

DUO MAX (TANDEM AXLE)

Model	Volume (M ³)	Augers	Dimensions (M)						
			Bin (mm)	Height (H)			Length (L) *	Width	
				tyre diameter				front discharge*	Bottom
				0.95 (STD)	0.8	1.051			
single axle 445/R45	tandem axle 30/11.5	tandem axle 435/50							
Mixell 16	16	2	1.70	2.65	2.50	2.75	7.18	2.25	2.25
Mixell 18	18	2	1.72	2.67	2.52	2.77	7.24	2.25	2.45
Mixell 20	20	2	1.90	2.85	2.70	2.95	7.30	2.25	2.42

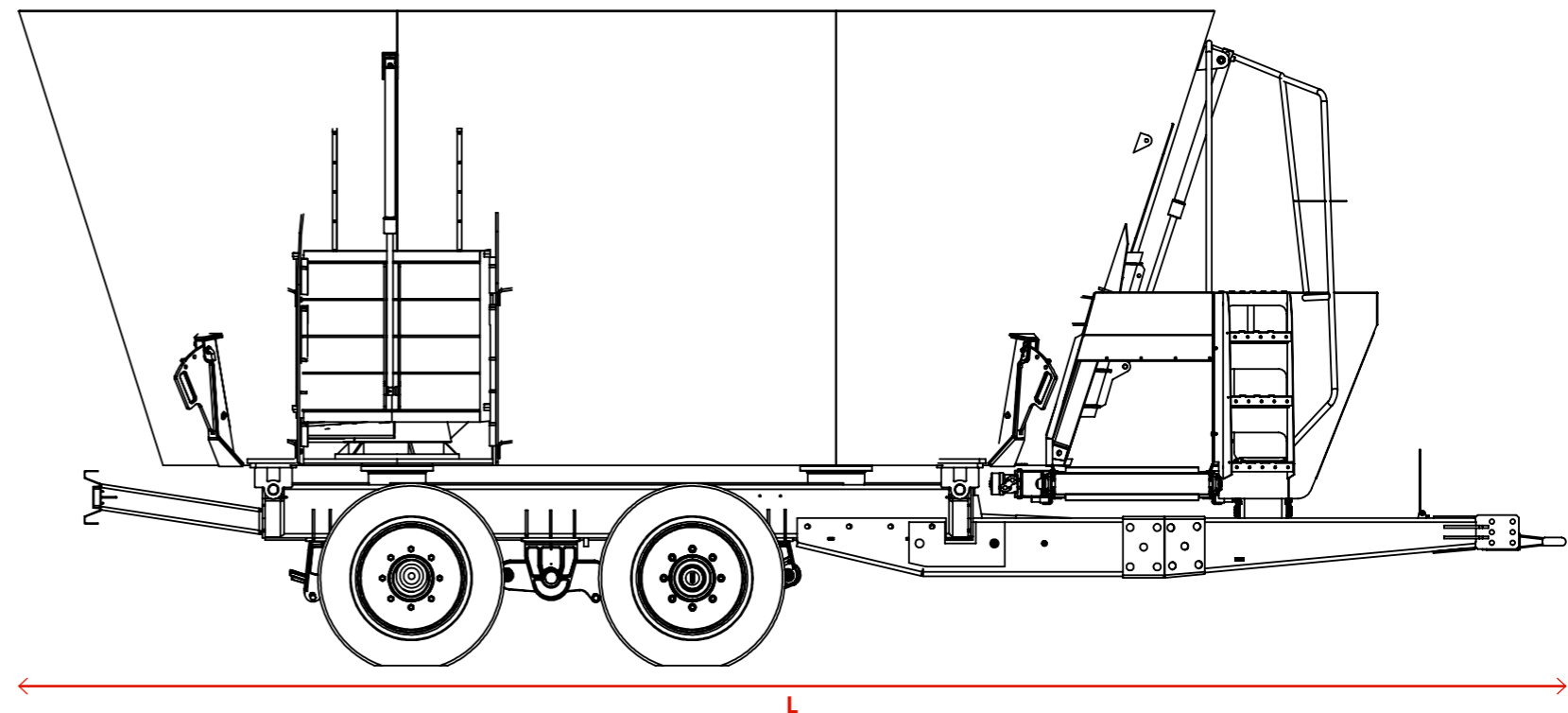

* Rear discharge shorter by 0.44 m

** Side door adds 0.1 m to overall width

Triple Auger | 30–45 m³

The go-to choice for very large herds and feed centers. Triple augers deliver throughput, consistency, and speed at scale.



Perfect Mix

Single auger with up to 66 knives for uniform TMR and optimal fiber length.



Worldwide Service

Trusted components & dealer network ensure easy maintenance and maximum uptime.



DuraCore Construction

3CR12 stainless steel in high-wear zones for long life and uptime.



TMR

Homogeneous TMR, optimal fiber length for herd health.



Fuel Consumption

VOLVO engine at 1700 rpm with load-sensing hydraulics.



Time Saver

Efficient operation, less machines, less rounds.



Key features

- Three overlapping augers- maximum mixing volume with uniform TMR.
- Heavy-duty chassis & driveline- multi-gearbox architecture, built for long runs.
- Precision discharge- multiple doors; customizable conveyor systems.
- Scale-ready- works seamlessly with central feed facilities and truck distribution.
- Options for longevity- stainless wear zones (3CR12), magnets, auto-greasing.

PTO horsepower depends on model, ration and workflow. Dimensions and weights may vary by configuration. For precise sizing, speak with your RMH dealer.

Maximum capacity. Unrivaled strength.

TRAILERS Technical Specifications

TRIO

Model	Volume (M ³)	Augers	Wheels		(Dimensions (M					
					Height (H)	Discharge Height		Length (L) *	Width	
			wheels (x6)	wheels (x4)	STD	door outlet	front conveyor	front discharge*	Bottom	Top**
Trio 30	30	3	315/60R-22.5	455/40-22.5	3.05	1.10	0.89	9.70	2.25	2.64
Trio 35	35	3	315/60R-22.6	455/40-22.5	3.20	1.10	0.89	9.70	2.25	2.65
Trio 40	40	3	315/60R-22.7	455/40-22.5	3.35	1.10	0.89	9.70	2.25	2.75
Trio 45	45	3	315/60R-22.8	455/40-22.5	3.50	1.10	0.89	9.70	2.25	2.80

* Rear discharge shorter by 0.44 m

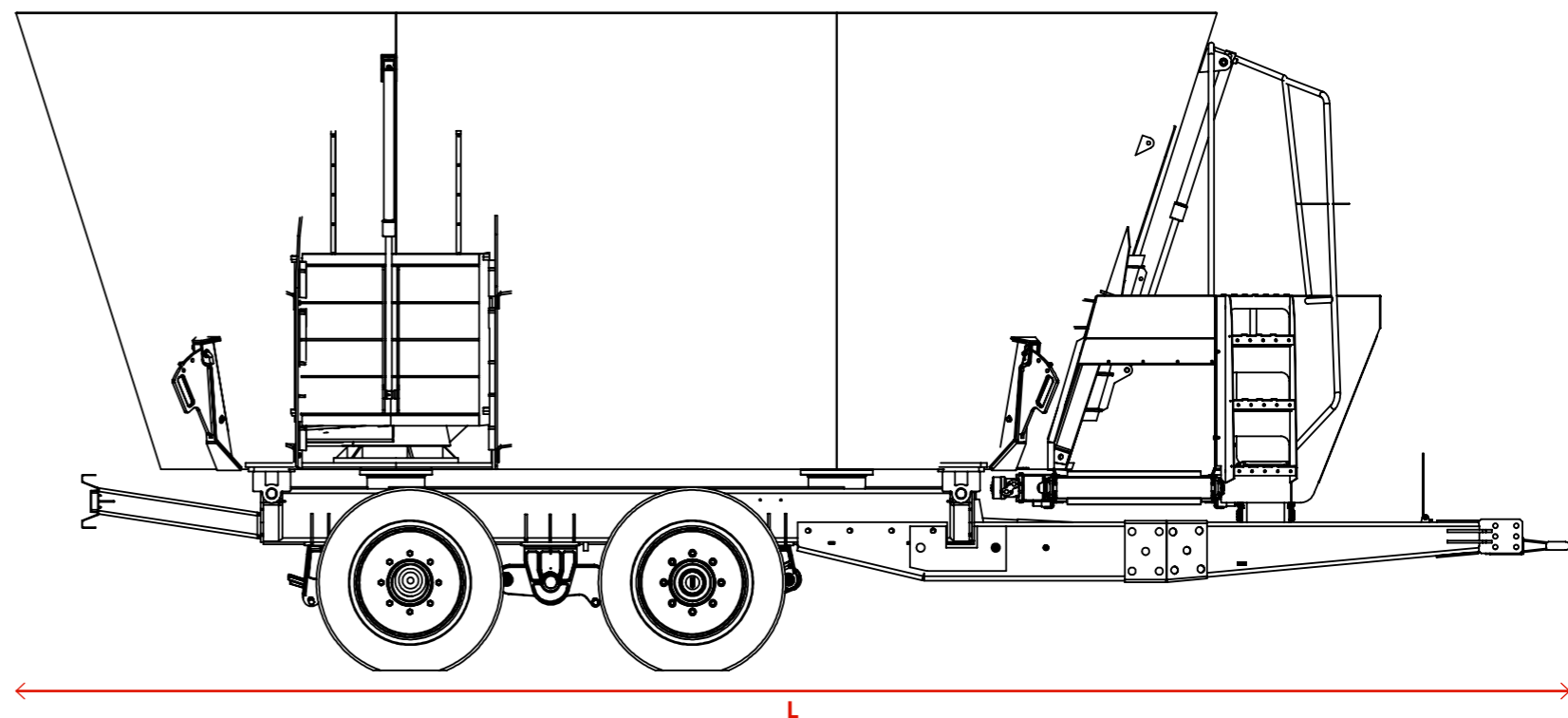
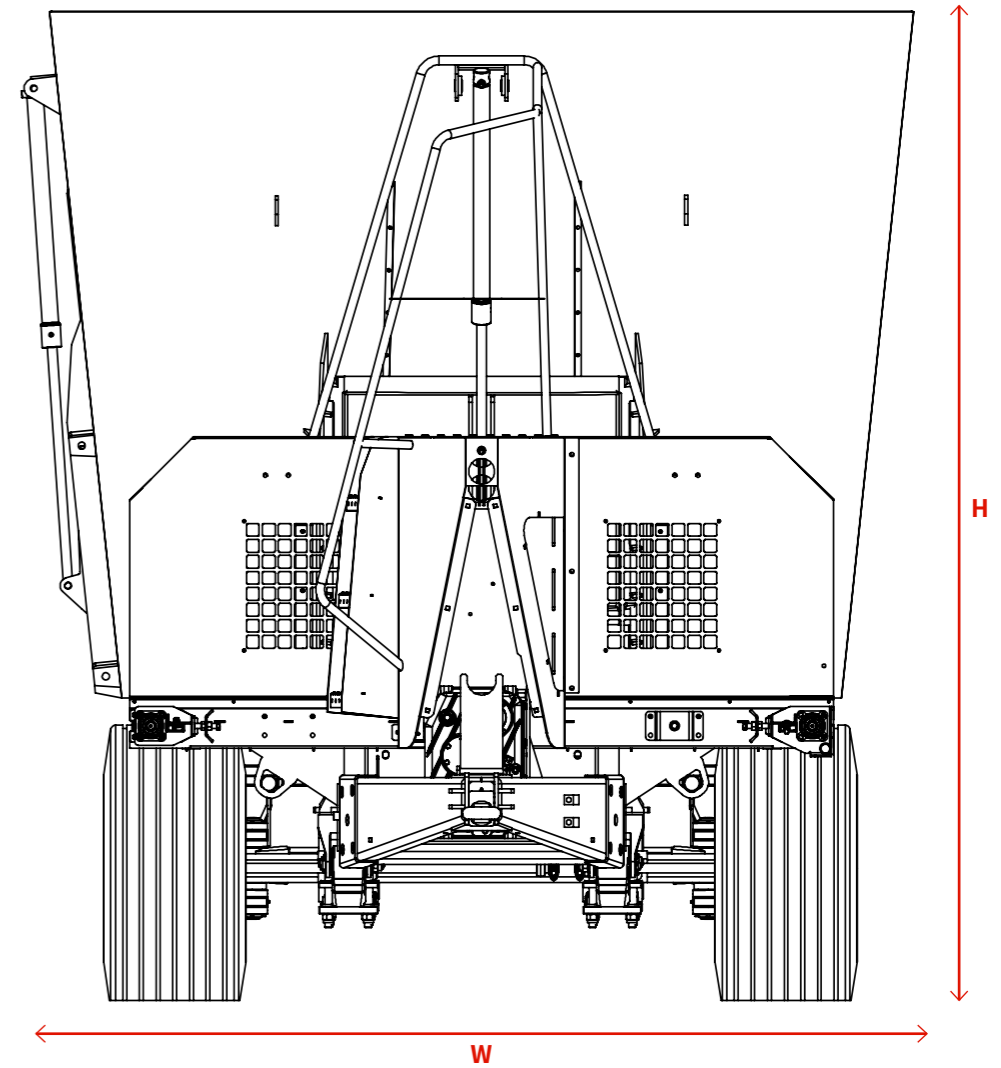



WWW.RMHMIXER.COM | INFO@RMHMIXER.COM

INDUSTRIAL ZONE SDEROT, P.O.B 105, 80100, ISRAEL

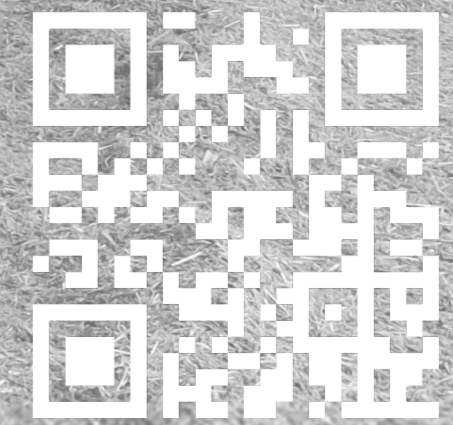

Follow Us

Engineered for Performance, Backed by Service. Contact us for a personalized demo and experience the RMH difference!

In the event of any inconsistency between the English version and any translation, the English version shall prevail. Specifications, configurations, and dimensions are subject to change without notice and may vary based on product customization.

BR0full catalog 29092025