



Self-Propelled
PREMIUM

15-24 m³

| Comfort and durability every day

RMH mixers are designed for maximum efficiency and reliability. With advanced features and a focus on seamless operation, they provide exceptional service and performance to maximize uptime.



Fuel Consumption

Low fuel consumption for cost-effective daily use.



Operator Environment

Upgraded air-conditioned cabin, XXL air suspended seat, intuitive controls & great visibility.



Advanced Drive System

Full four-wheel drive and steering for confident navigation in any terrain.



Worldwide Service

Trusted components & dealer network ensure easy maintenance and maximum uptime.



CutControl

Hydraulic harvesting and cutting system for precise, efficient feed loading.



TMR

Uniform mix with optimal fiber length for better intake and healthier herds.

**Based on comparative studies with leading competitor models. Results may vary based on operational conditions.*



Energy-Efficient & Built to Last

Quick-access engine area.

Comprehensive worldwide parts availability and local expert technical support.

Optional automatic greasing system.

Running at 1700 RPM to minimize wear while maintaining optimal performance.



Seamless Operation & Maximum Comfort

Ergonomic work area.

Multi-camera system (rear, mixing chamber, optional sides).

Advanced suspension for all-day comfort.

User-friendly controls, designed for both operators and technicians.





Compact Yet Powerful

- Crab mode - ideal for manoeuvring in tight spaces.
- Fits on road and off road driving.
- 4x4 steering and driving to overcome challenging terrains with PTO axle connection.
- Up to 40 km/h top speed for quick feeding cycles.

Perfect Mix

- Overlapping twin vertical augers ensure a homogeneous, fluffy mix that maximizes nutritional value.
- Hydraulically operated contra knives for optimal cutting efficiency.
- Mixing bin top options (cover/fiber).
- Optional 3CR12 stainless steel.



SafeFeed

- Customizable distribution system: up to 4 doors and 3 portable conveyors for even feed distribution.
- Made from 3CR12 stainless steel with C55 chain, ensuring longevity.

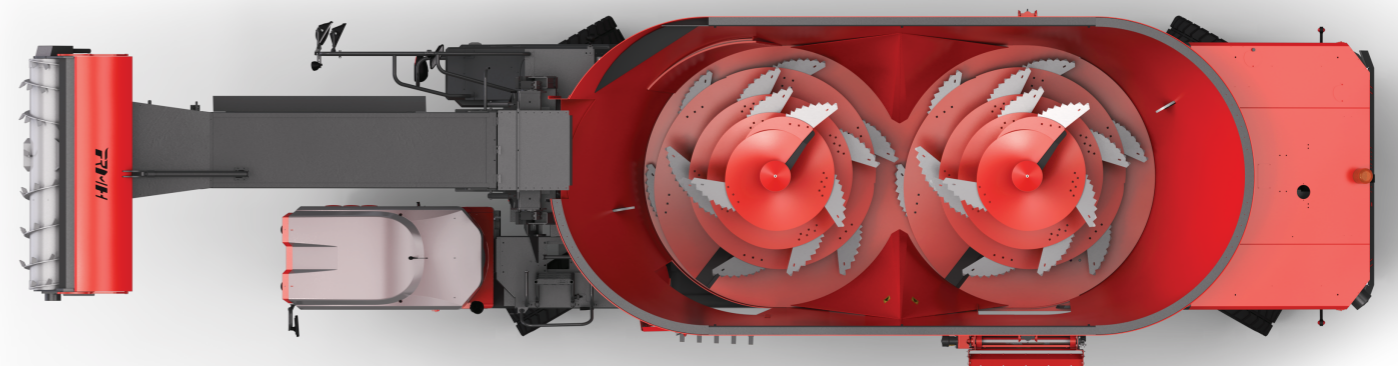

Efficient And Productive, Every Time

- Computerized management system reducing energy consumption and extending component lifespan.
- Optional 3CR12 stainless steel front spiral chopper, built for durability.
- 650 mm-wide rubber belt loading elevator for fast and even distribution.



Vitamins Compartment

- Easily add supplements to enhance cattle nutrition.
- Improve yield by preserving nutritional value.
- Save time on feeding routines.

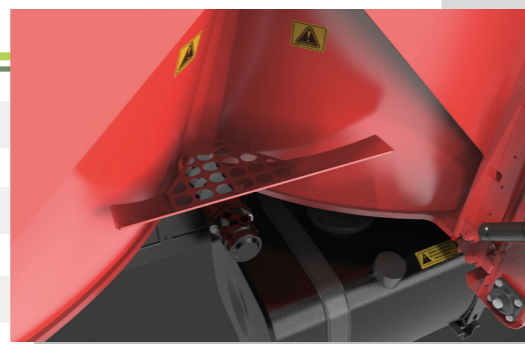

PREMIUM Technical Specifications

A	Specifications	Premium 15	Premium 17	Premium 18	Premium 20	Premium 22	Premium 24	Premium 22 low	Premium 24 low
1	Volume [cu. mt.]	15	17	18	20	22	24	22	24
2	Max Load [kg]	6000	6800	7200	8000	8800	9600	8800	9600
3	Engine H.P	215 / 208							
4	Engine Manufacturer	Volvo/Deutz							
5	Overall Length [mm]	9760			9650			10600	
6	Overall Height [mm]	2770	2970	2820	3000	3170	3450	2900	3100
7	Overall Width [mm]	2260	2260	2500	2500	2600	2630	2500	2500
8	Chopper Width [mm]	2014							
9	Chopper Dia. [mm]	600							
10	Chopper Height [mm]	4800	5000	4800	4900	4900	4900	4780	4780
11	Loading Elevator Belt [mm]	650							
12	Discharge Height [mm]	780						805	
13	Wheel Dia. [mm]	1072							
14	Wheel Base [mm]	5350						6050	
15	Steering Radius [mm]	6748						7585	
16	Ground Clearance [mm]	270						310	
17	4 Wheel Steering	Yes							
18	Driving Speed [KPH]	25/40							
19	No. of STD Choper Knives	66							
20	No. of STD Mixer Knives	8 / 11	9 / 12	8 / 11	9 / 12	10 / 13	10 / 13	10	10
21	Bin Wall Thickness [mm]	6							
22	Mixer Segment Thickness [mm]	16/14							
23	Mixer Speed [rpm]	15-44							
24	Elevated Cab.	No							
25	3CR12 Option	Bin, Augers, Chopper, Loading Elevator							

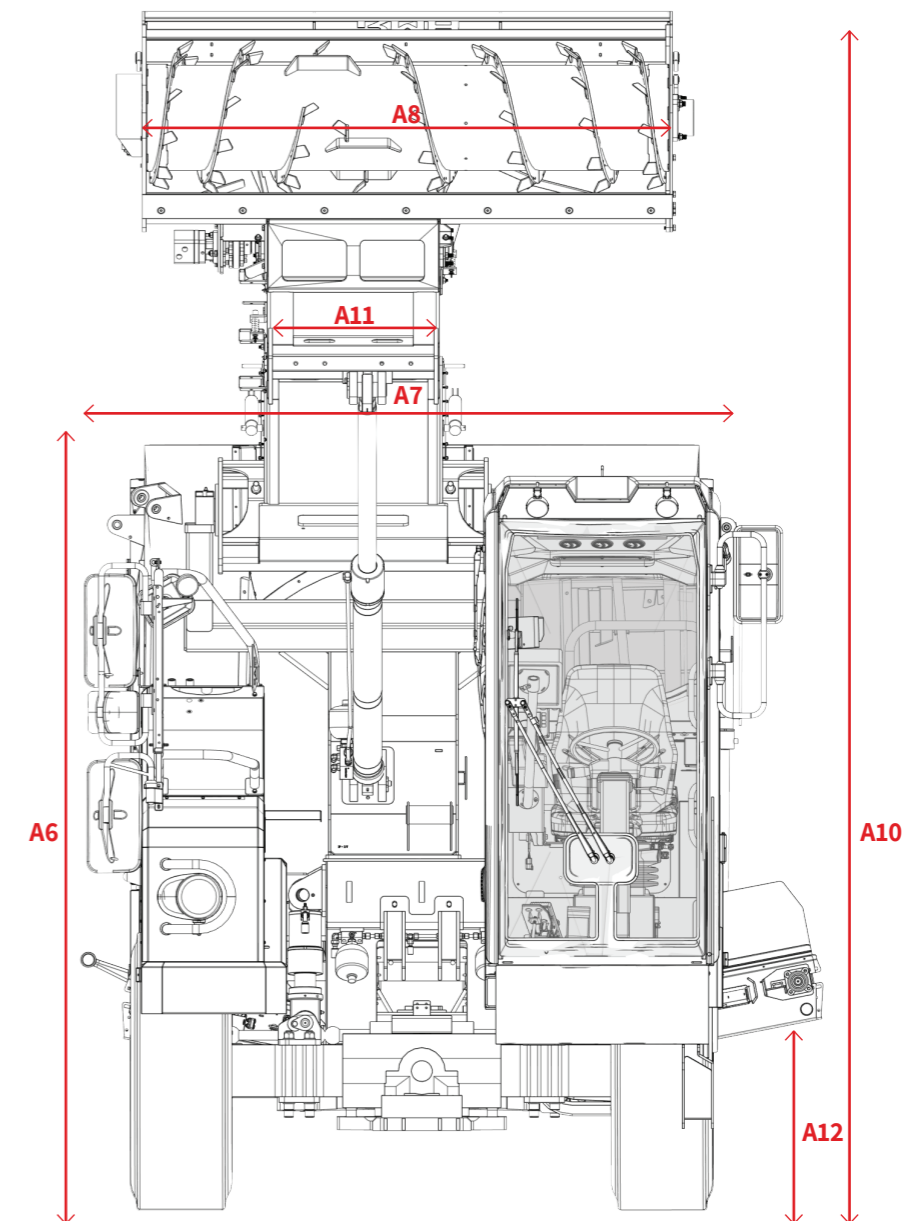
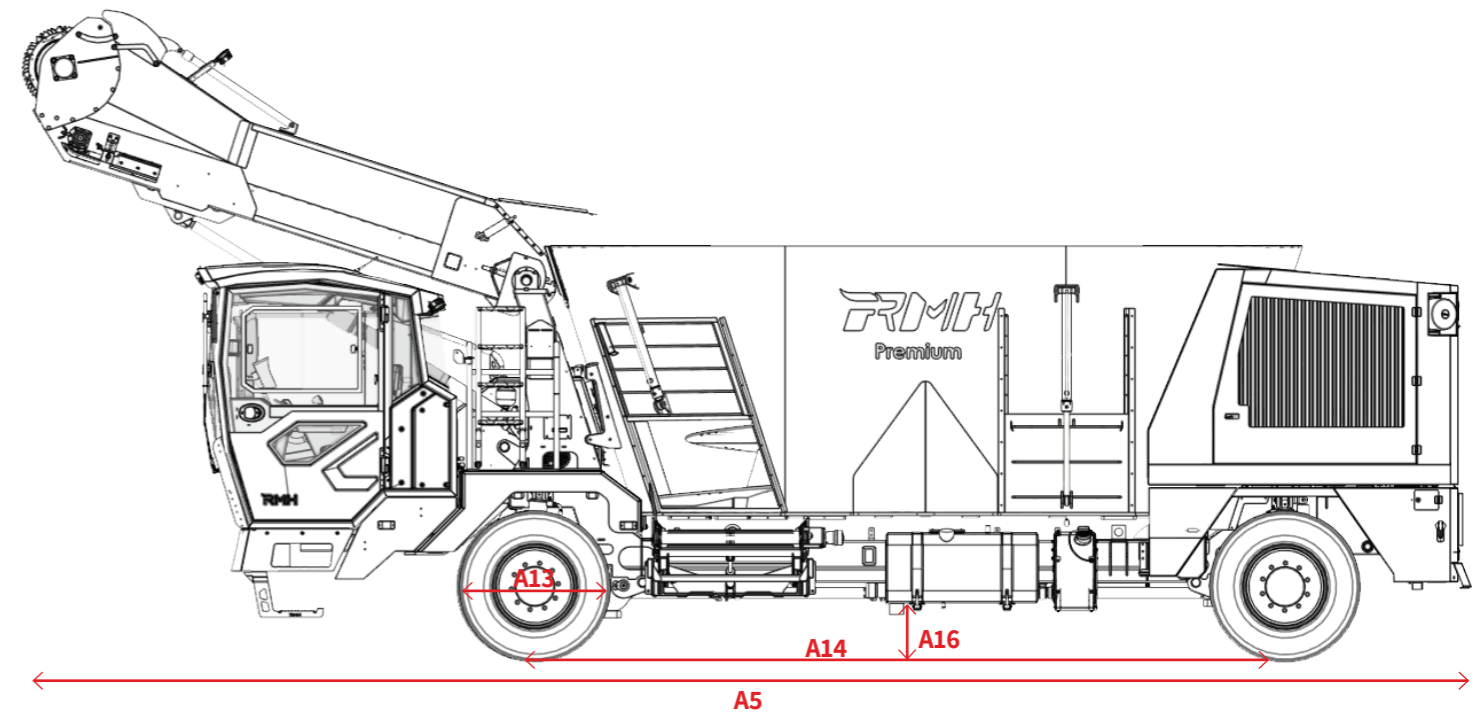



WWW.RMHMIXER.COM | INFO@RMHMIXER.COM

INDUSTRIAL ZONE SDEROT, P.O.B 105, 80100, ISRAEL

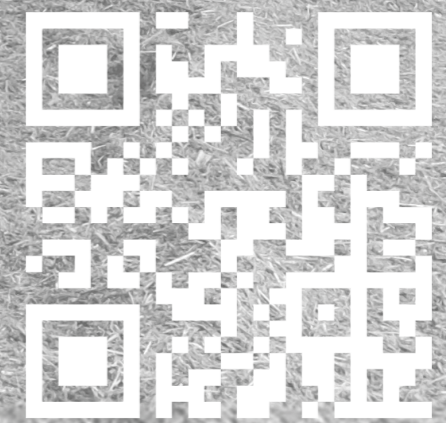

Follow Us

Engineered for Performance, Backed by Service. Contact us for a personalized demo and experience the RMH difference!

In the event of any inconsistency between the English version and any translation, the English version shall prevail. Specifications, configurations, and dimensions are subject to change without notice and may vary based on product customization.