



Self-Propelled  
**LIBERTY**

11-15 m<sup>3</sup>

| Compact power for small herds

**RMH mixers are designed for maximum efficiency and reliability.** With advanced features and a focus on seamless operation, they provide exceptional service and performance to maximize uptime.



**Fuel Consumption**

135 HP DEUTZ engine with load-sensing hydraulics - <0.9 L/ton.



**Operator Environment**

Upgraded air-conditioned cabin, XXL air suspended seat, intuitive controls & great visibility.



**Perfect Mix**

Single auger + counter-knives - consistent, fluffy TMR.



**Worldwide Service**

Trusted components & dealer network ensure easy maintenance and maximum uptime.



**DuraCore Construction**

3CR12 stainless protection for durability in high-wear zones.



**Advanced Drive System**

Rear steering + compact size - smooth turns in narrow barns.

*\*Based on comparative studies with leading competitor models. Results may vary based on operational conditions.*



**Reliable And Cost-Efficient**

135 HP DEUTZ engine at 1700 rpm.  
Load-sensing hydraulics reduce pump wear.



**Ergonomic And Accessible**

Air-conditioned cabin with XXL Grammer seat.  
Easy access, wide visibility, simple controls.



## Compact And Easy To Handle

Rear steering axle for smooth turning in tight spaces.

Narrow frame ideal for small yards and narrow barns.



## Efficient And Consistent

Single vertical auger with hydraulic counter-knives.

Front spiral chopper with 3CR12 stainless housing.

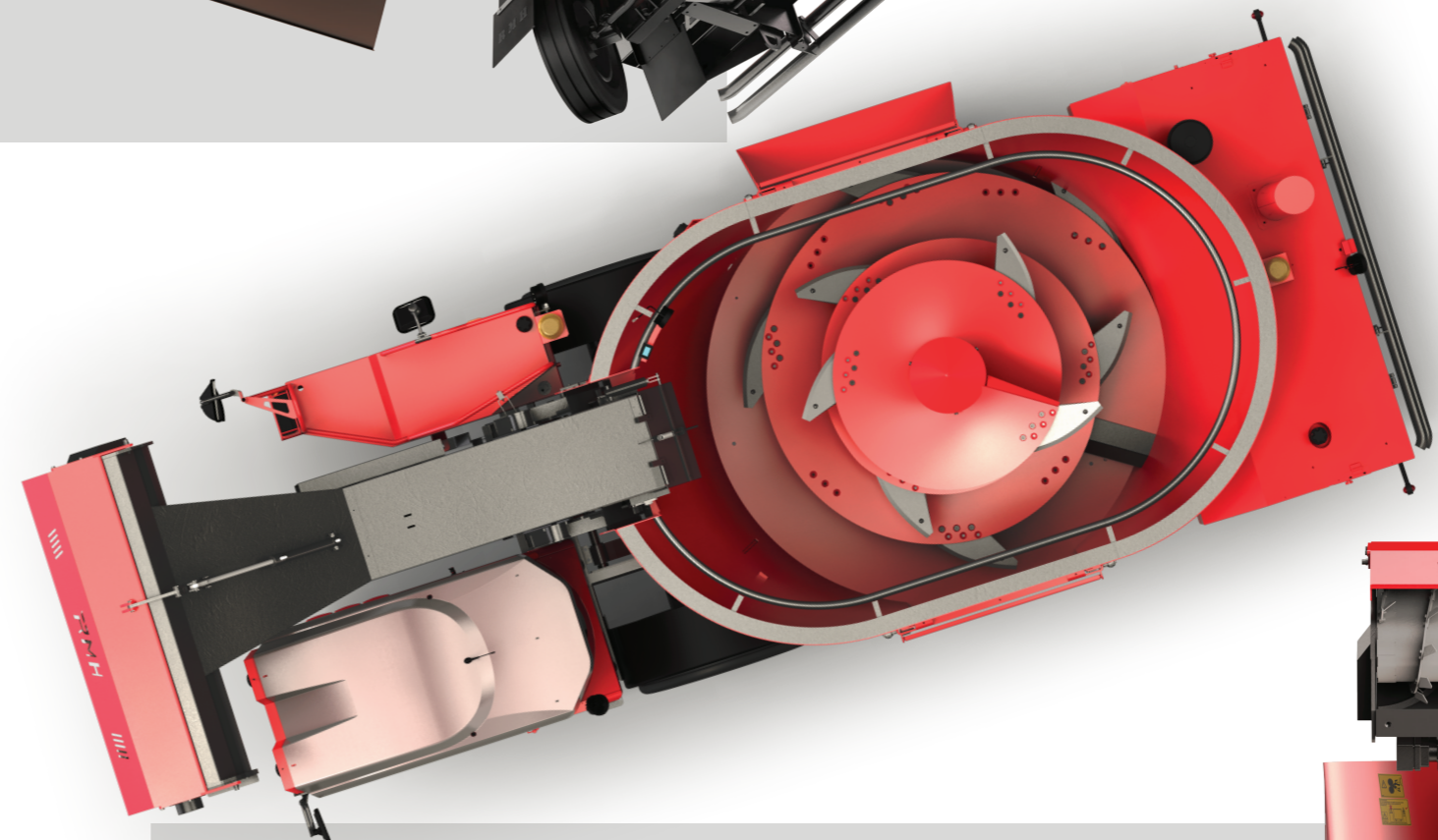

## Accurate And Adjustable

Electro-hydraulic discharge with folding conveyor.

Magnetic safety filter (optional).



## Durable By Design

Optional 3CR12 stainless steel in high-wear areas.

Compact build with low center of gravity.



# LIBERTY Technical Specifications

A	Specifications	Liberty 11	Liberty 12	Liberty 13	Liberty 14	Liberty 15	Liberty 13XL	Liberty 14XL	
1	Volume [cu. mt.]	11	12	13	14	15	13	14	
2	Max Load [kg]	4400	4800	5200	5600	6000	5200	5600	
3	Engine H.P	135							
4	4 cylinders Engine Manufacturer	Deutz							
5	Overall Length [mm]	6750	6650		6865		6840		
6	Overall Height [mm]	2535	2678	2828	2900	3000	2828		
7	Overall Width [mm]	2250					2400		
8	Chopper Width [mm]	1784				1840	1784		
9	Chopper Dia. [mm]	600							
10	Chopper Height [mm]	3589	4070		3650		4070		
11	Loading Elevator Belt [mm]	500							
12	Discharge Height [mm]	460							
13	Wheel Dia. [mm]	940							
14	Wheel Base [mm]	2740							
15	Steering Radius [mm]	5713							
16	Ground Clearance [mm]	320							
17	Rear Steering	Yes							
18	Driving Speed [KPH]	12/24							
19	No. of STD Choper Knives	60							
20	No. of STD Mixer Knives	9				8			
21	Bin Wall Thickness [mm]	4							
22	Mixer Segment Thickness [mm]	12 / 14							
23	Mixer Speed [rpm]	15-44							
24	Elevated Cab.	No							
25	3CR12 Option	Bin, Augers, Chopper, Loader Elevation							

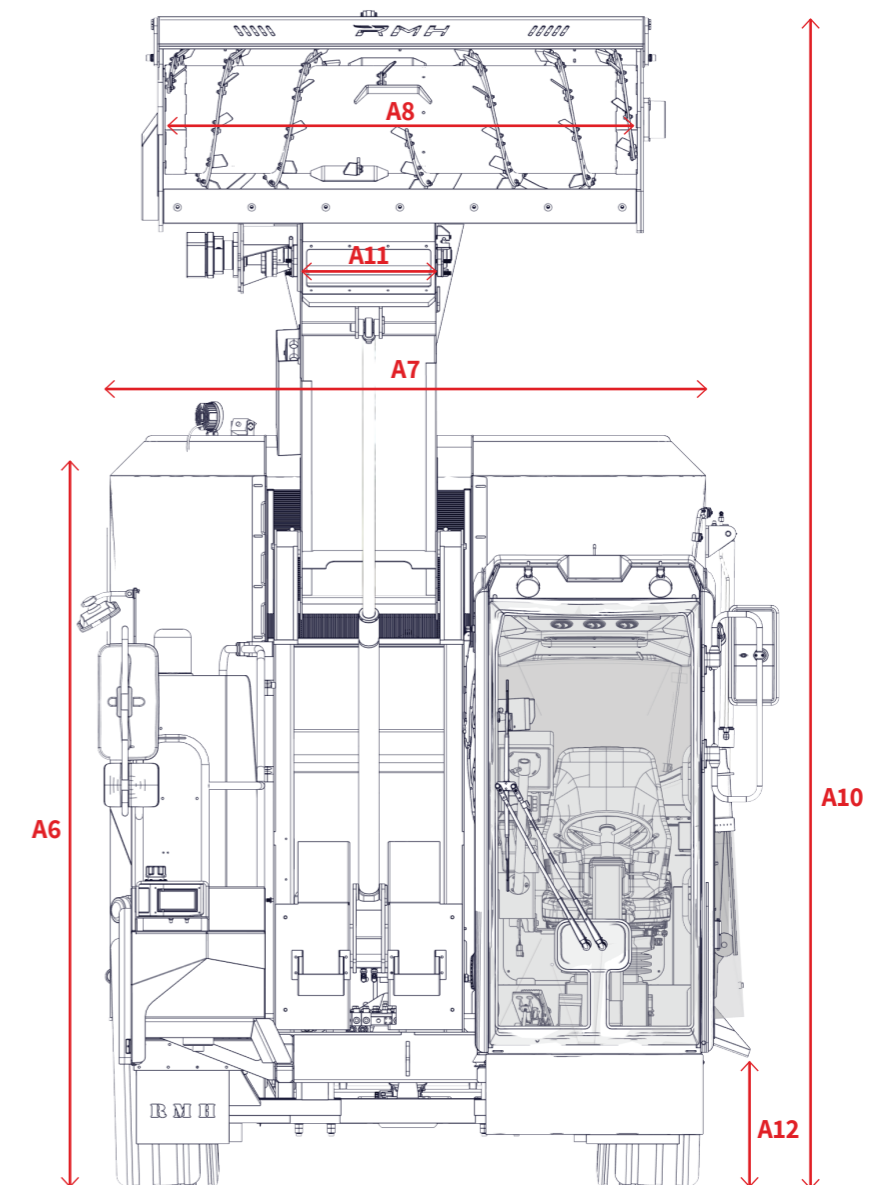
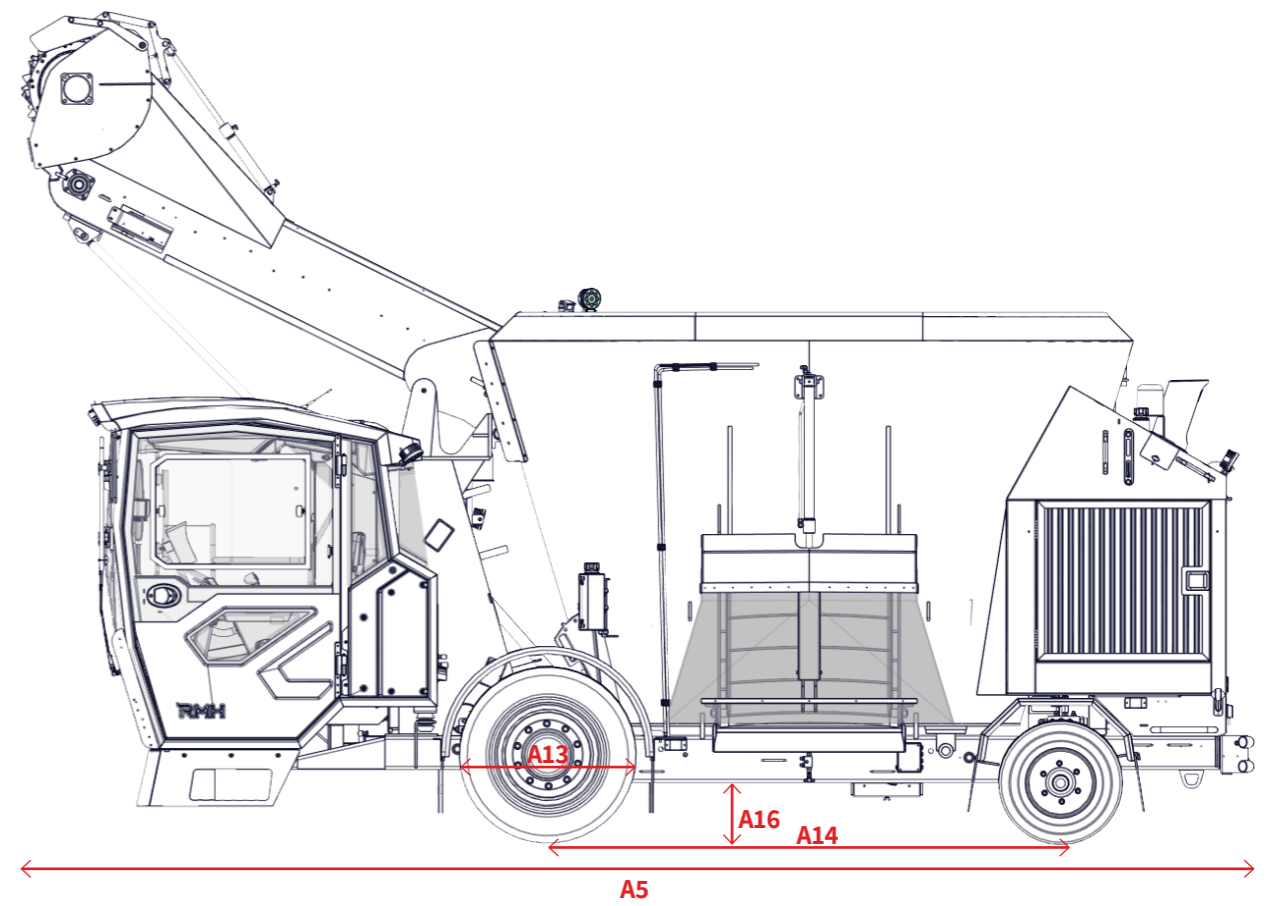



[WWW.RMHMIXER.COM](http://WWW.RMHMIXER.COM) | [INFO@RMHMIXER.COM](mailto:INFO@RMHMIXER.COM)

INDUSTRIAL ZONE SDEROT, P.O.B 105, 80100, ISRAEL

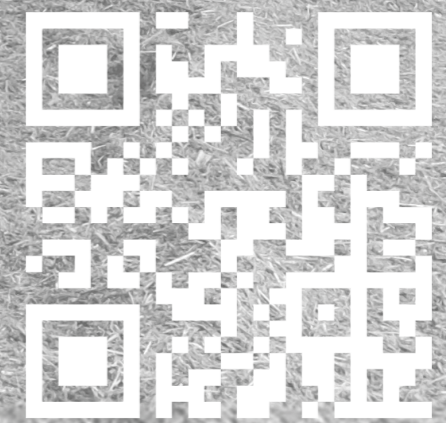

Follow Us

**Engineered for Performance, Backed by Service. Contact us for a personalized demo and experience the RMH difference!**

In the event of any inconsistency between the English version and any translation, the English version shall prevail. Specifications, configurations, and dimensions are subject to change without notice and may vary based on product customization.

BR0full catalog 29092025