



# DELIVERY TRUCK

## Smart, Operator-Friendly Systems

Dual side conveyors, full in-cab controls, and load-sensing hydraulics make every unloading smooth, accurate, and efficient. Built-in weighing systems keep you on track, while the hermetic top cover keeps feed fresh on the move.

Hydraulics- proportional main pump with selector; smooth, responsive operation.

Weighing sub-chassis- multi-loadcell design for on-the-go accuracy.

In-cab control panel- simple, intuitive, operator-friendly.



## Durability Meets Daily Performance

Purpose-built components, integrated hydraulics and pneumatics, and compatibility with your truck platform – together they deliver long-term reliability, minimal downtime, and feeding precision your farm can depend on



# DELIVERY TRUCK Technical Specifications

Model	Volume (M <sup>3</sup> )	Augers (crumbler)	Box Dimensions (M)			
			Height (H)	Length (L)	Width	
					Bottom	Top
DT 15	15	1	1.42	6.22	2.55	2.55
DT 29	29	2	1.90	7.70	2.55	2.55
DT 30	30	2	2.00	7.70	2.55	2.55

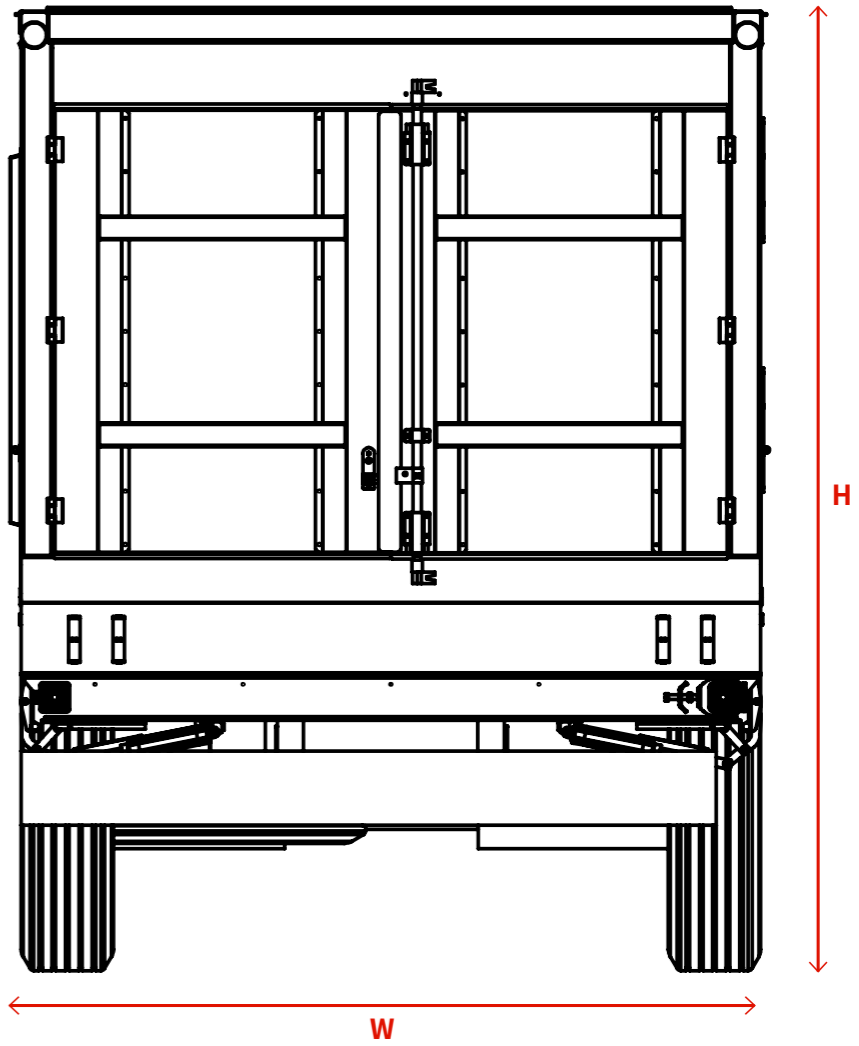
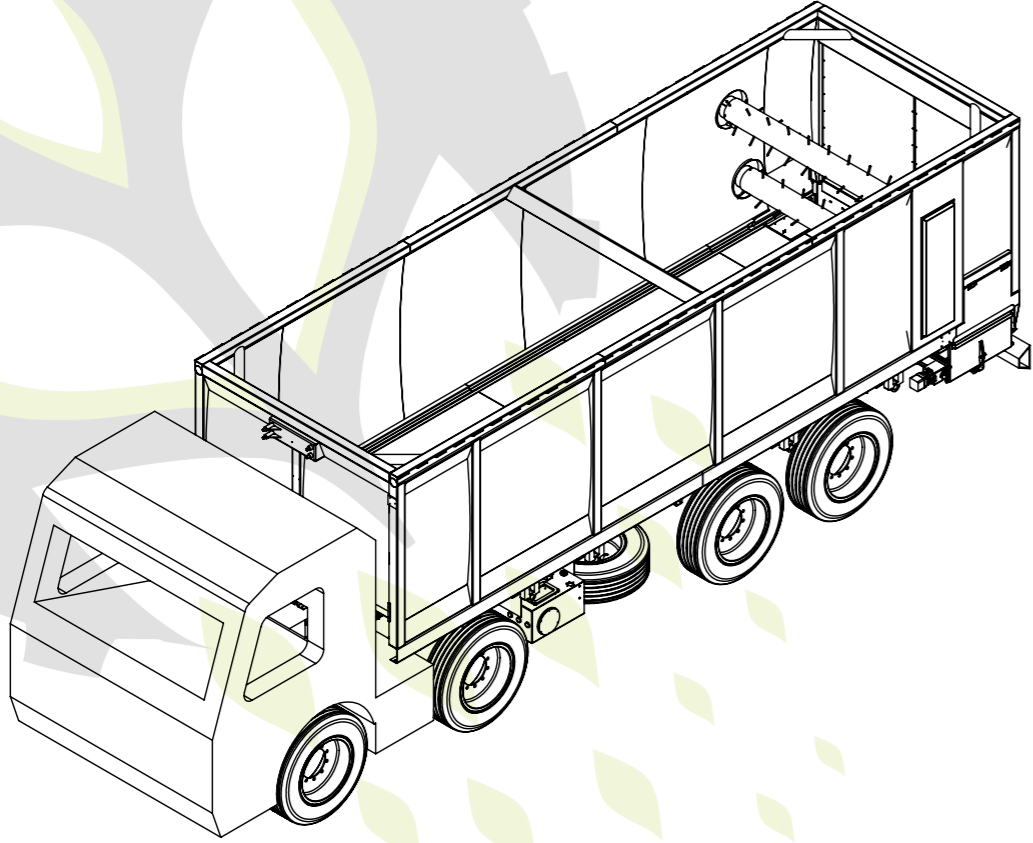
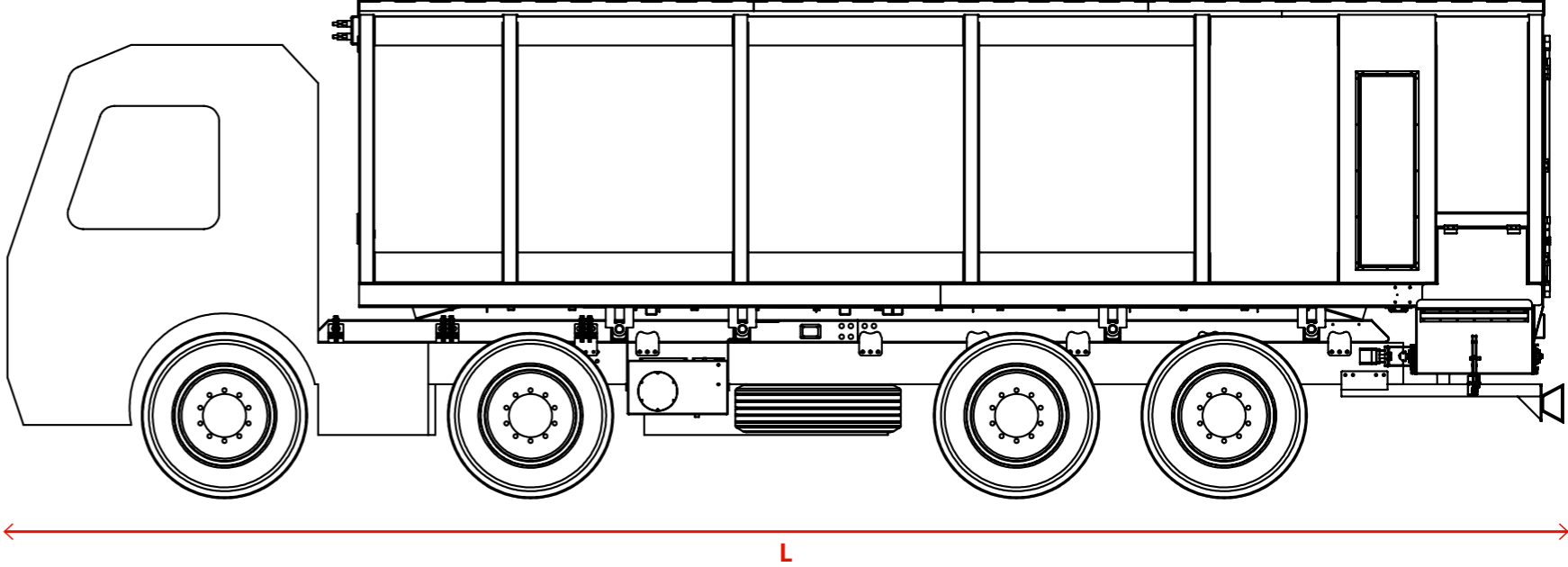



[WWW.RMHMIXER.COM](http://WWW.RMHMIXER.COM) | [INFO@RMHMIXER.COM](mailto:INFO@RMHMIXER.COM)

INDUSTRIAL ZONE SDEROT, P.O.B 105, 80100, ISRAEL

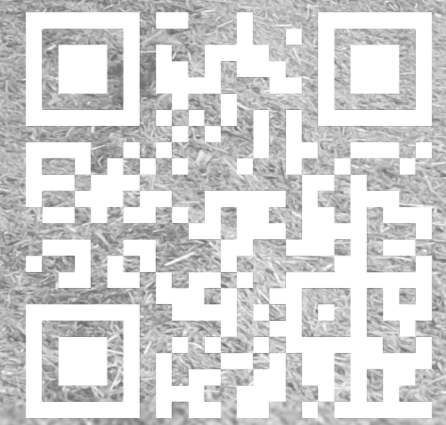

**Follow Us**

**Engineered for Performance, Backed by Service. Contact us for a personalized demo and experience the RMH difference!**

In the event of any inconsistency between the English version and any translation, the English version shall prevail. Specifications, configurations, and dimensions are subject to change without notice and may vary based on product customization.

BR0full catalog 29092025